

1

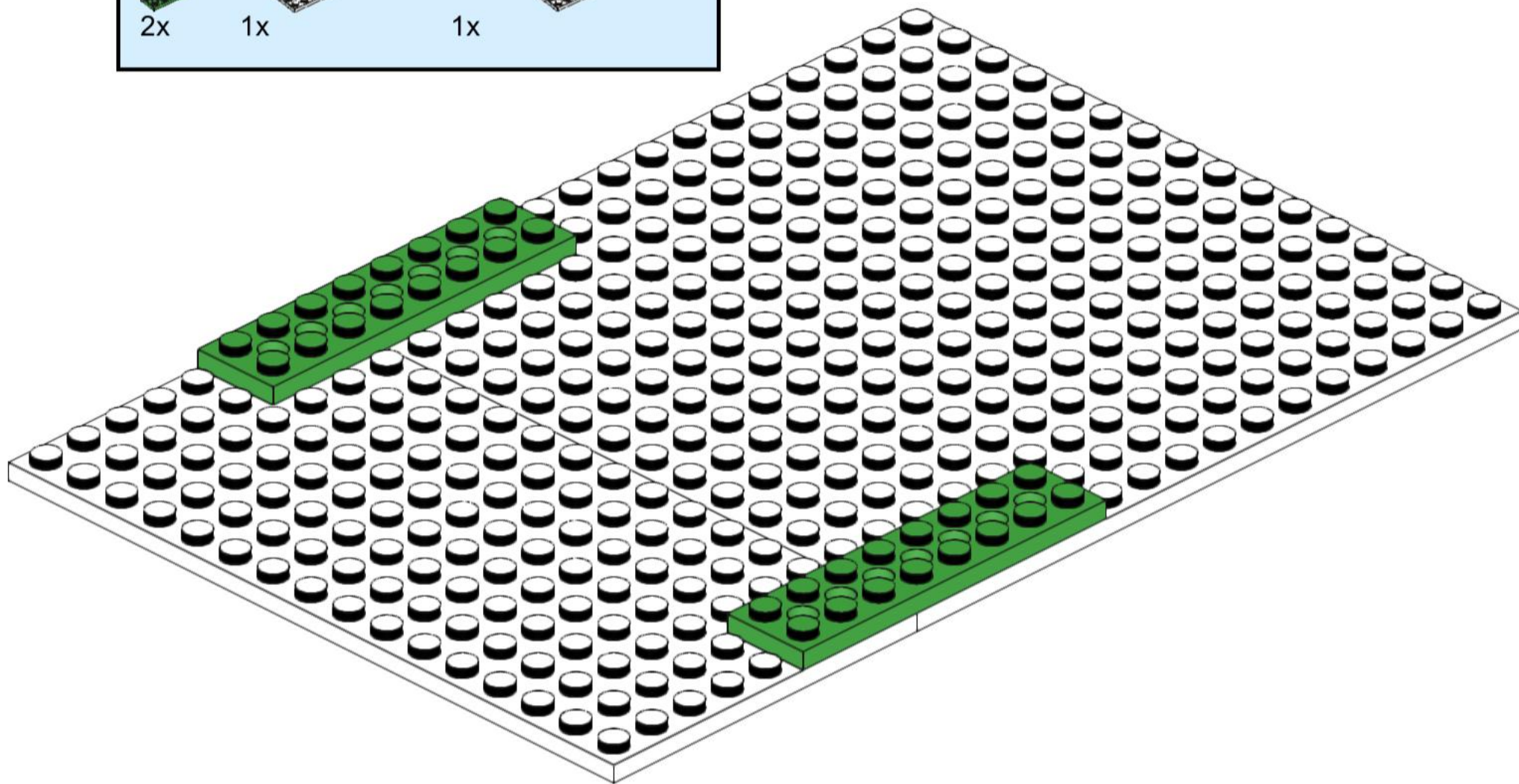

3

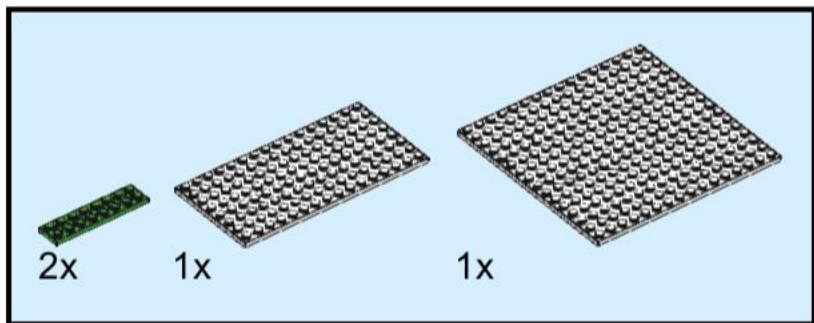
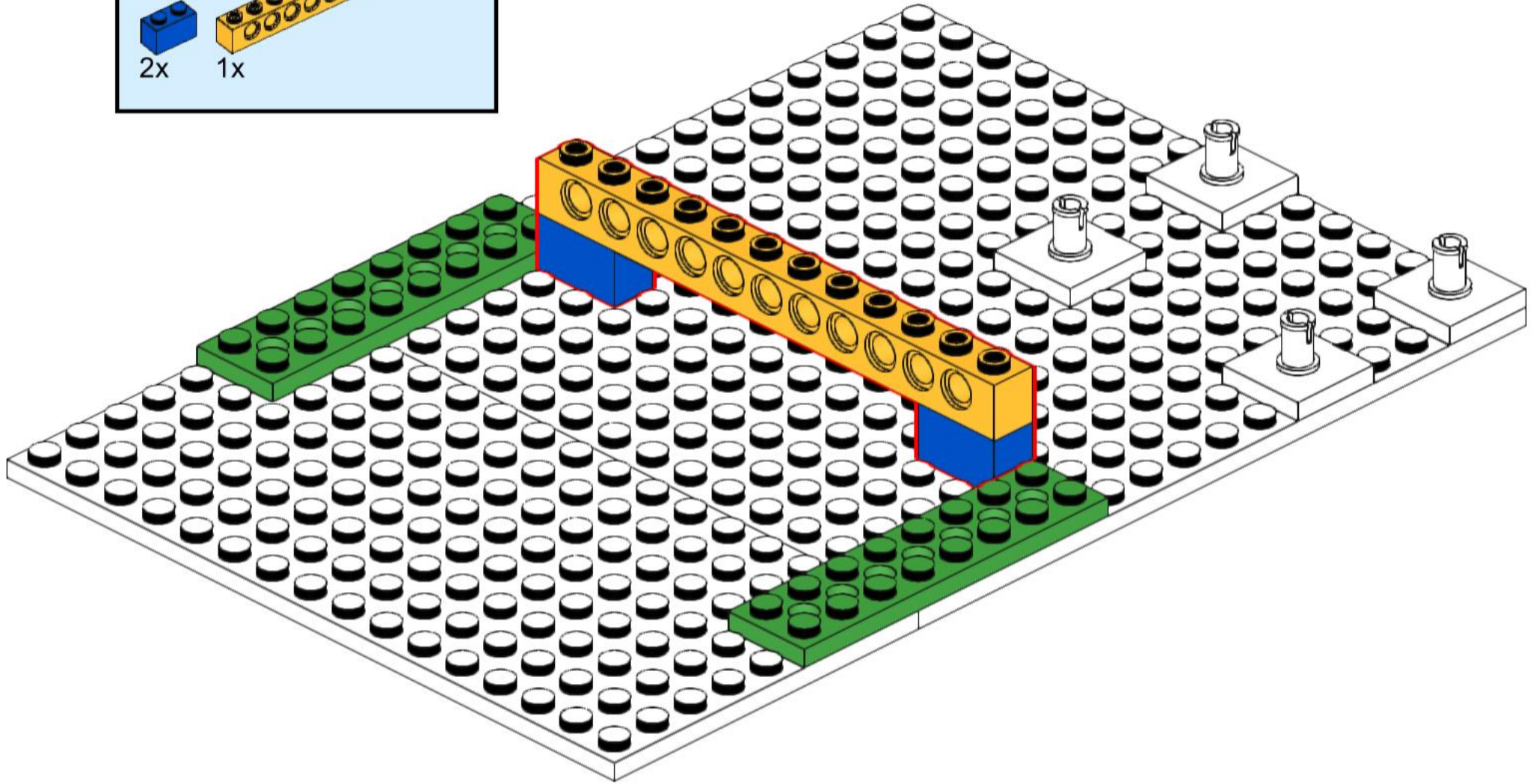
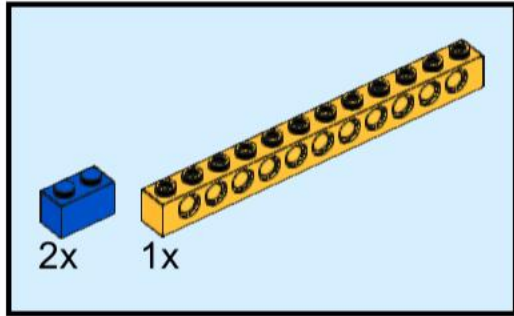

4

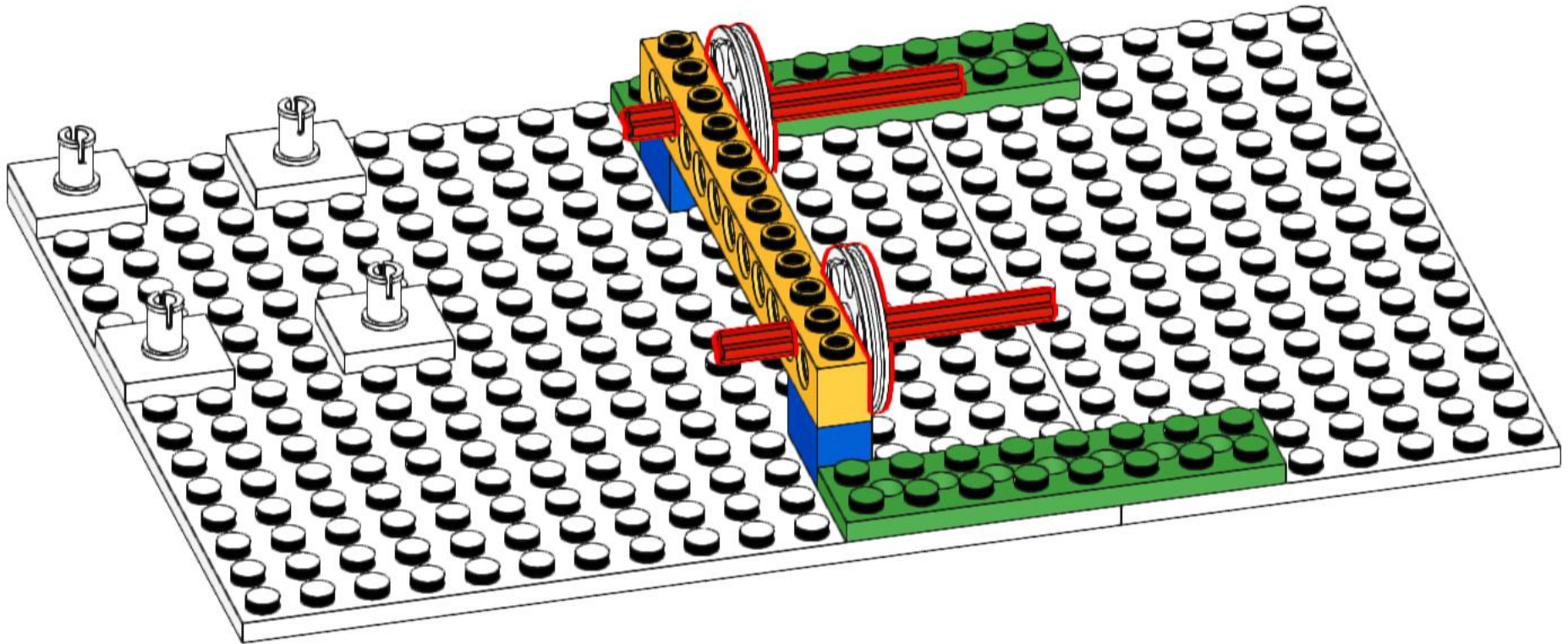
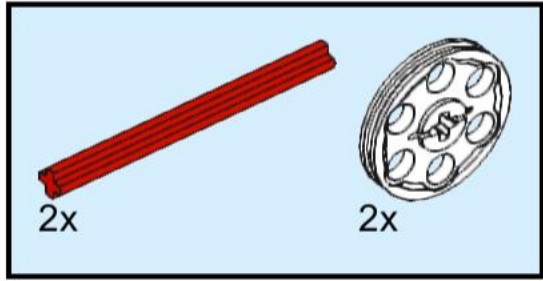

6

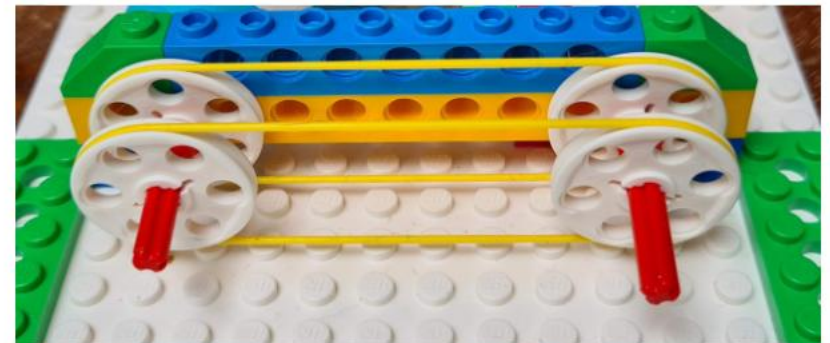
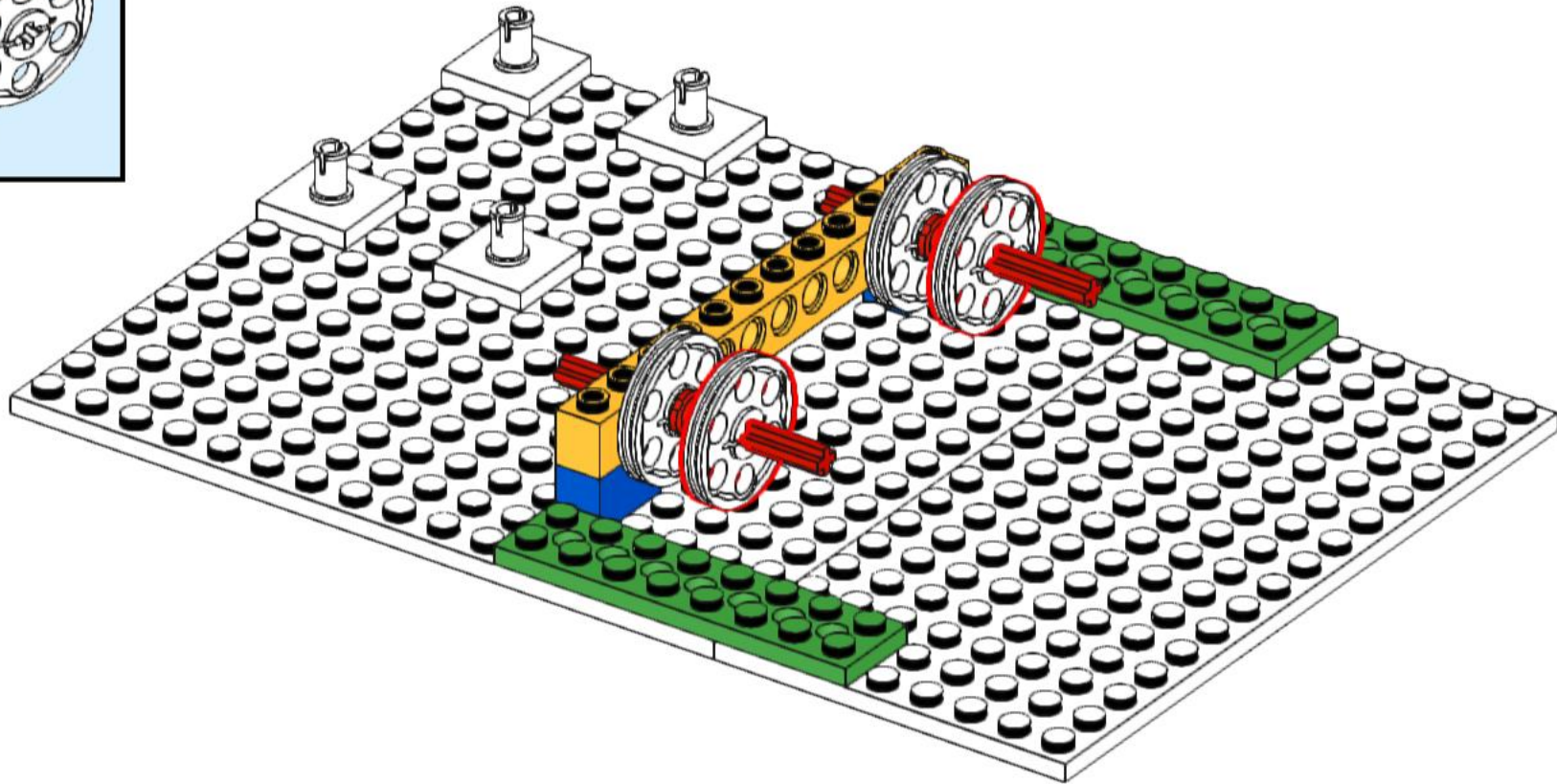
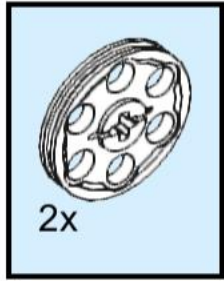

6a: Doe nu de gele elastiekjes om de wielen

7

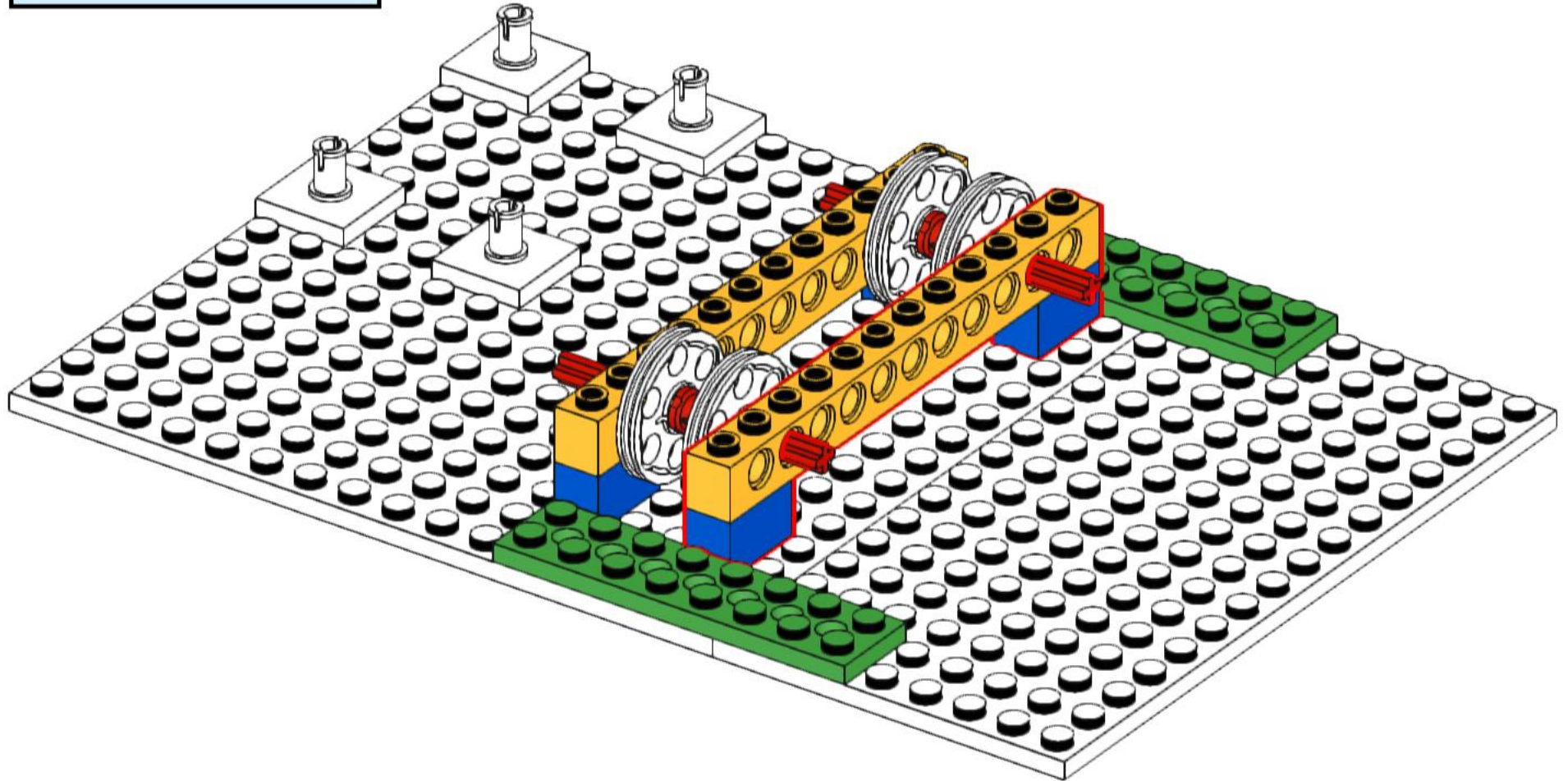
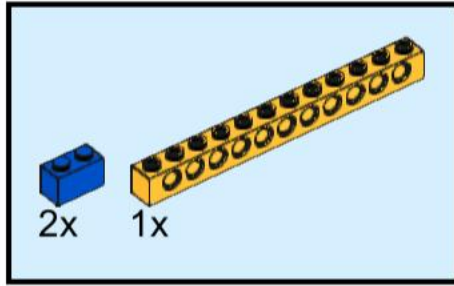

8

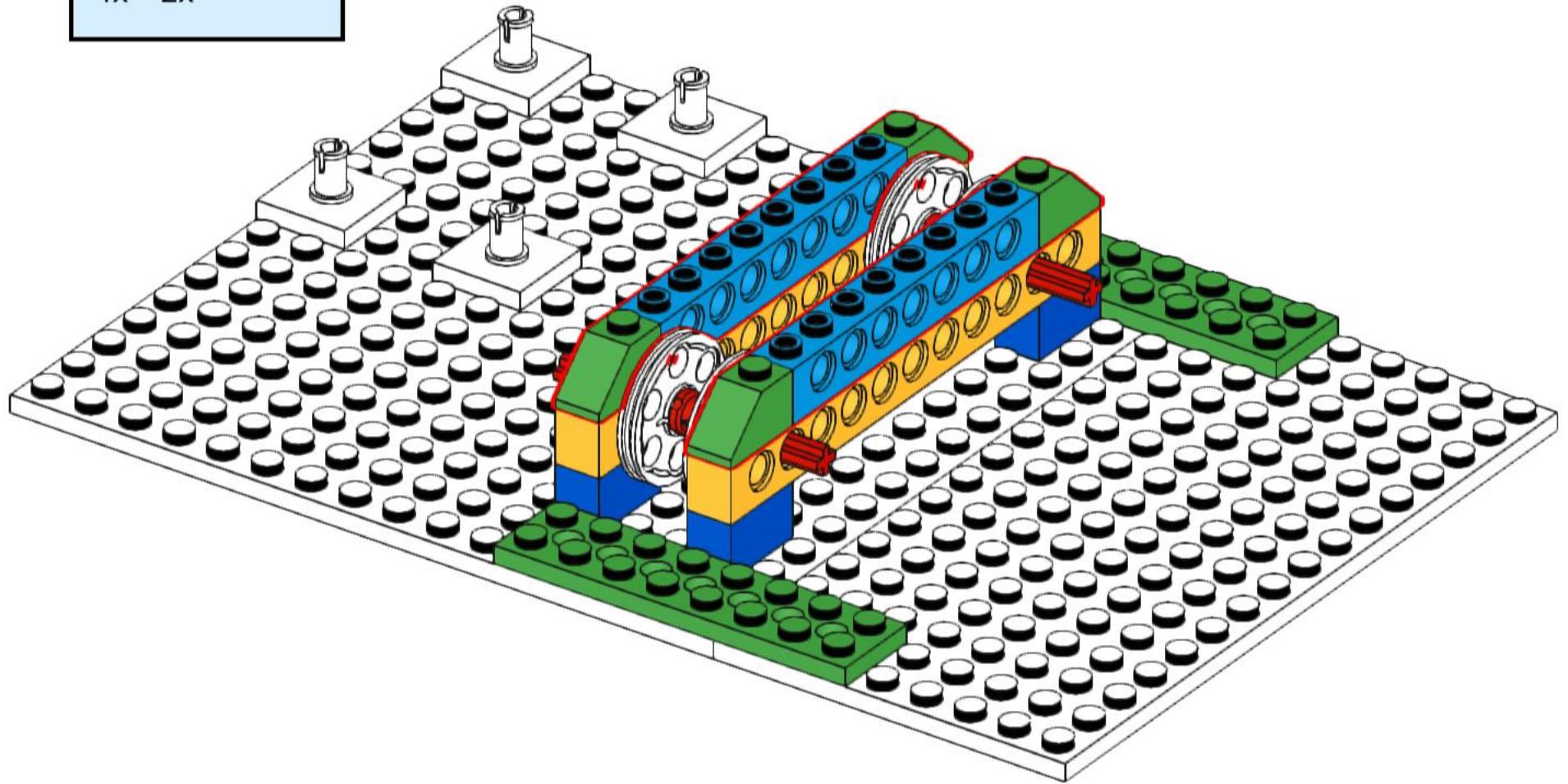
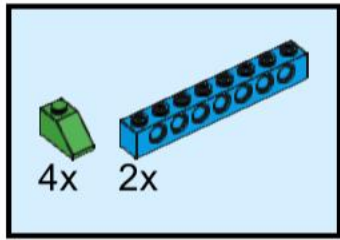

9

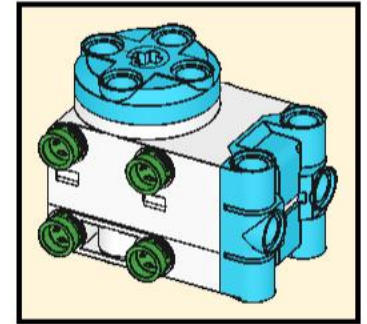
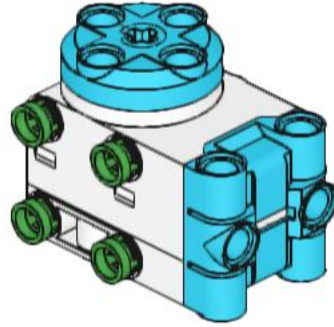
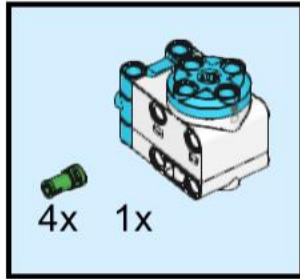

10

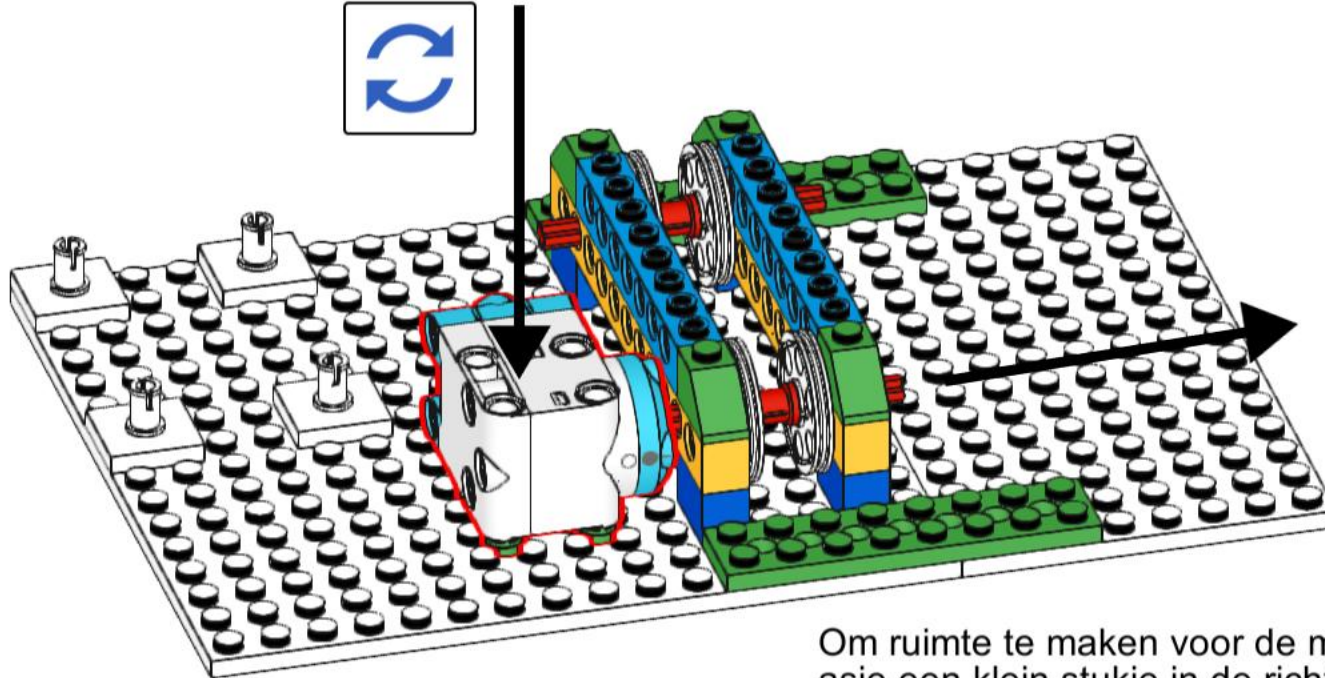

Om ruimte te maken voor de motor kan je het rode asje een klein stukje in de richting van de pijl duwen. Als de motor op zijn plek staat, moet je het asje weer terugduwen, in de motor.

11

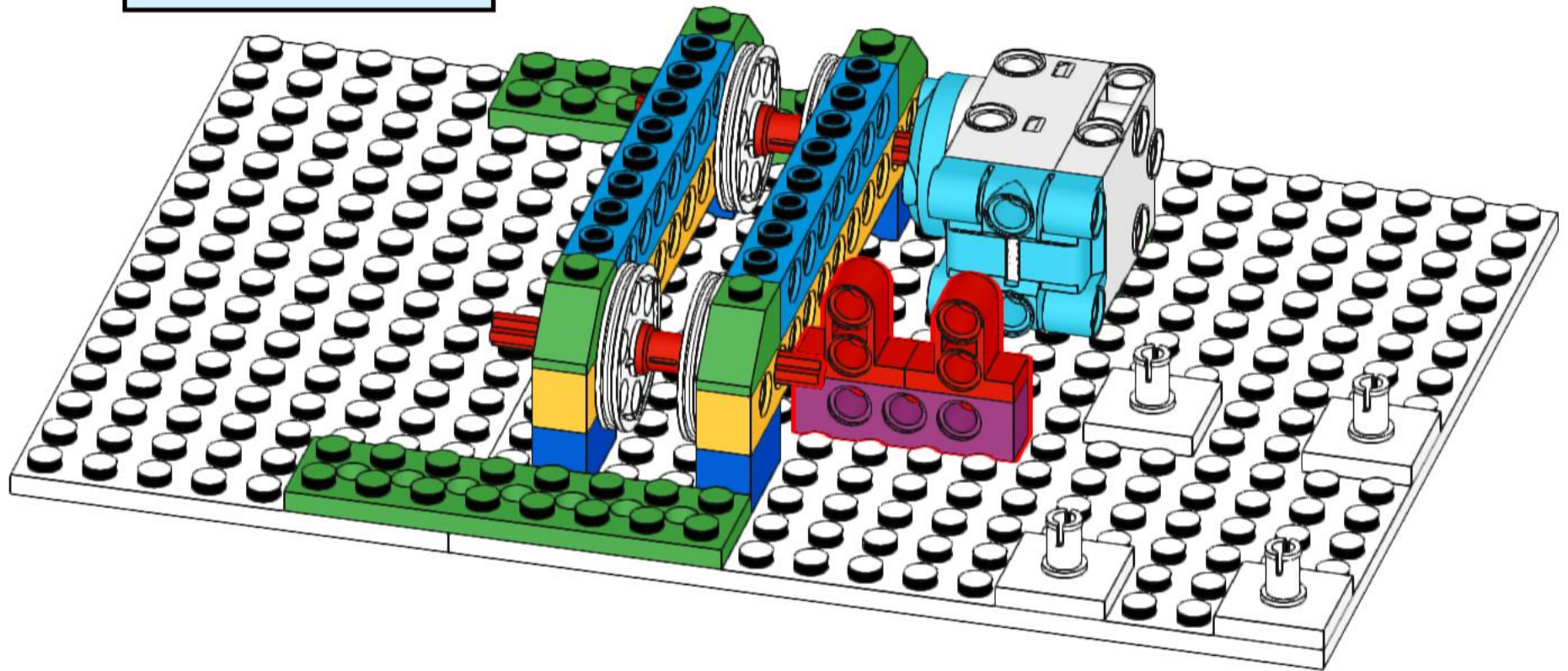
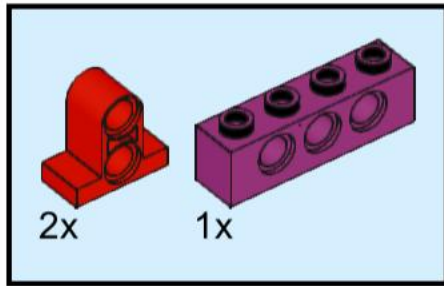

12

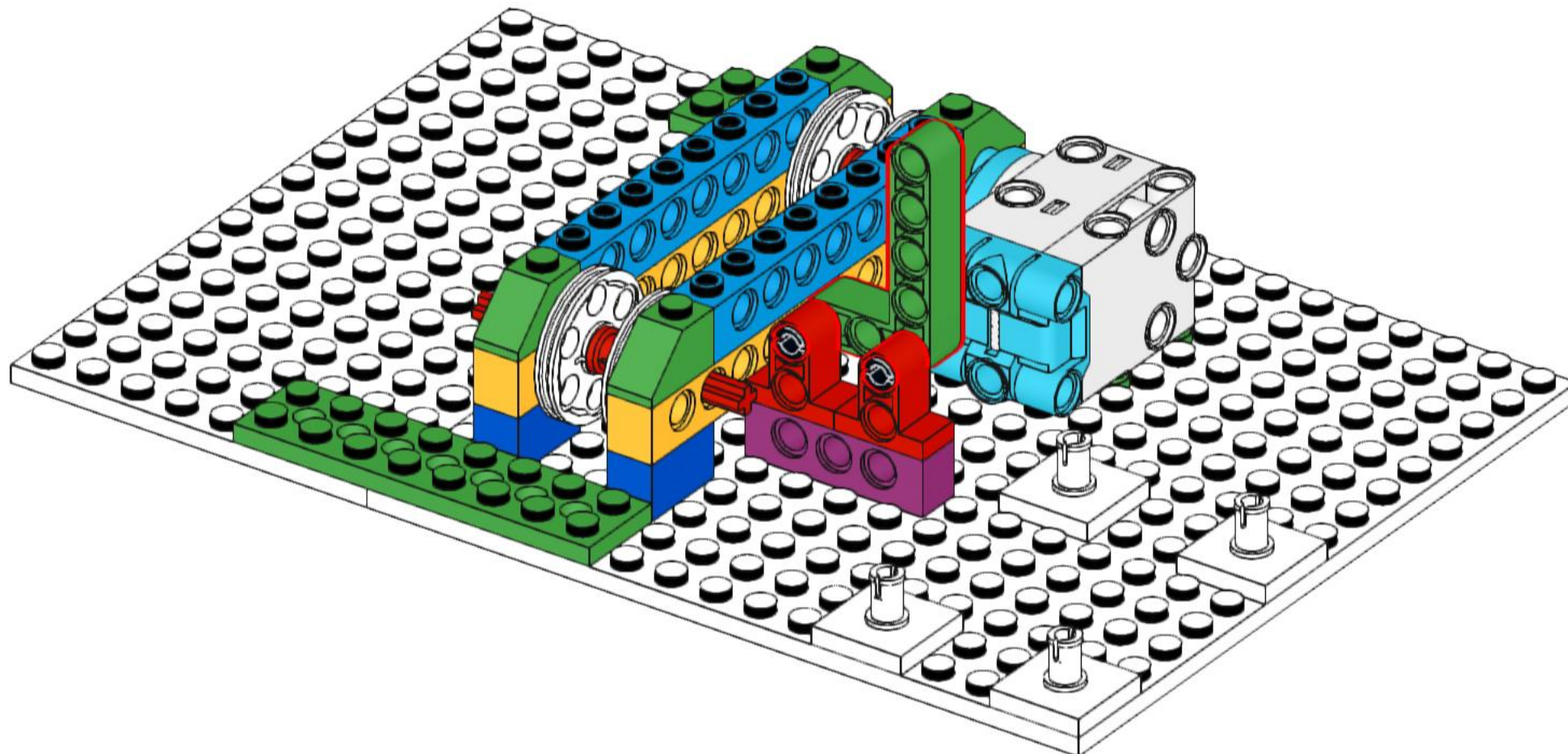
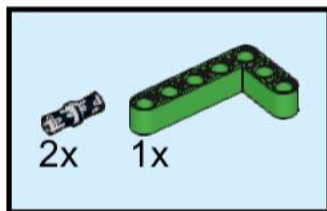

14

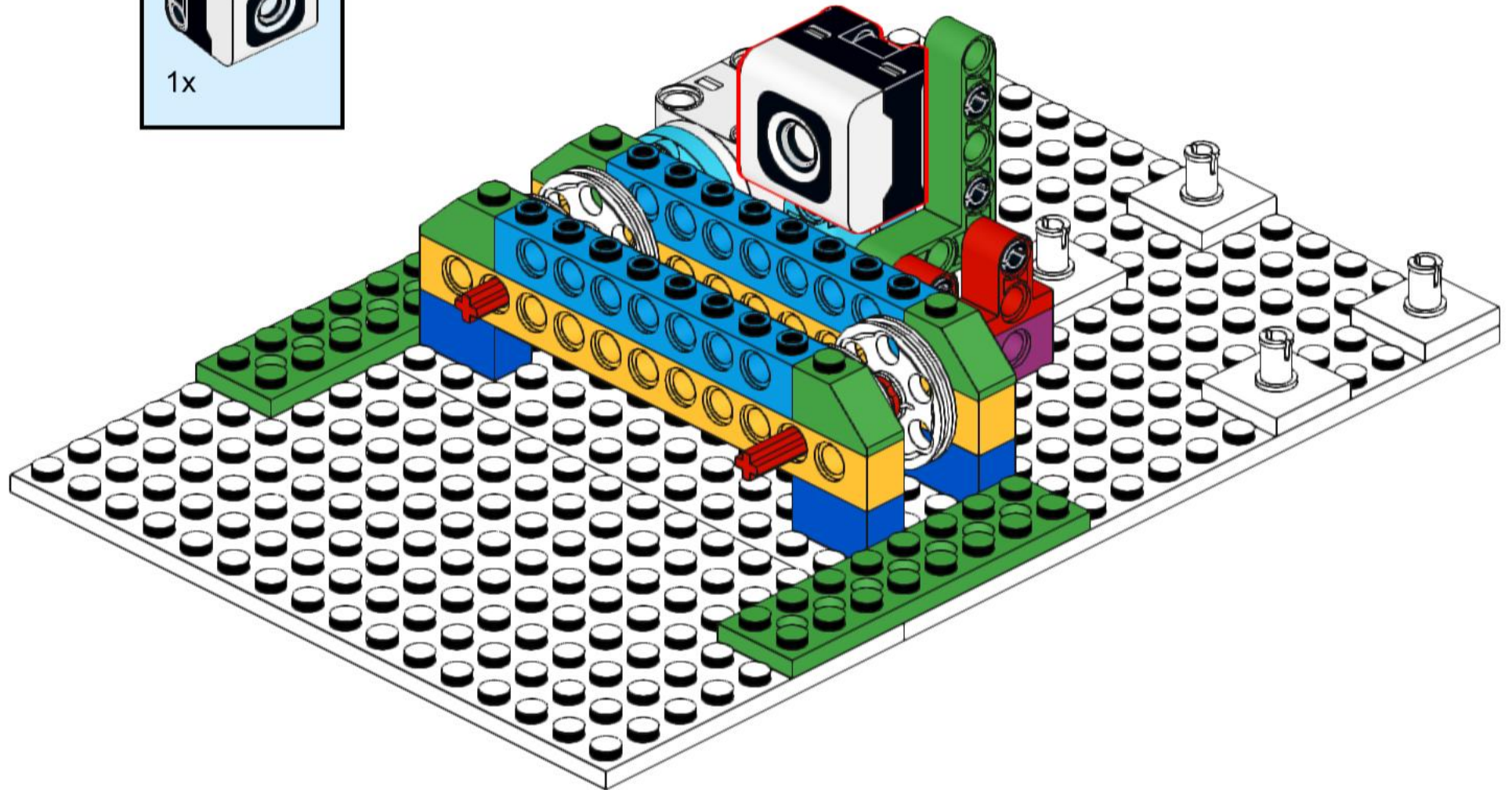
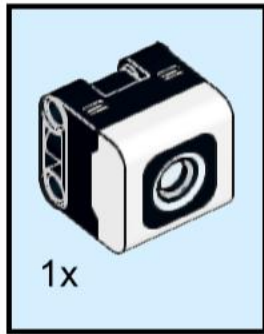

15

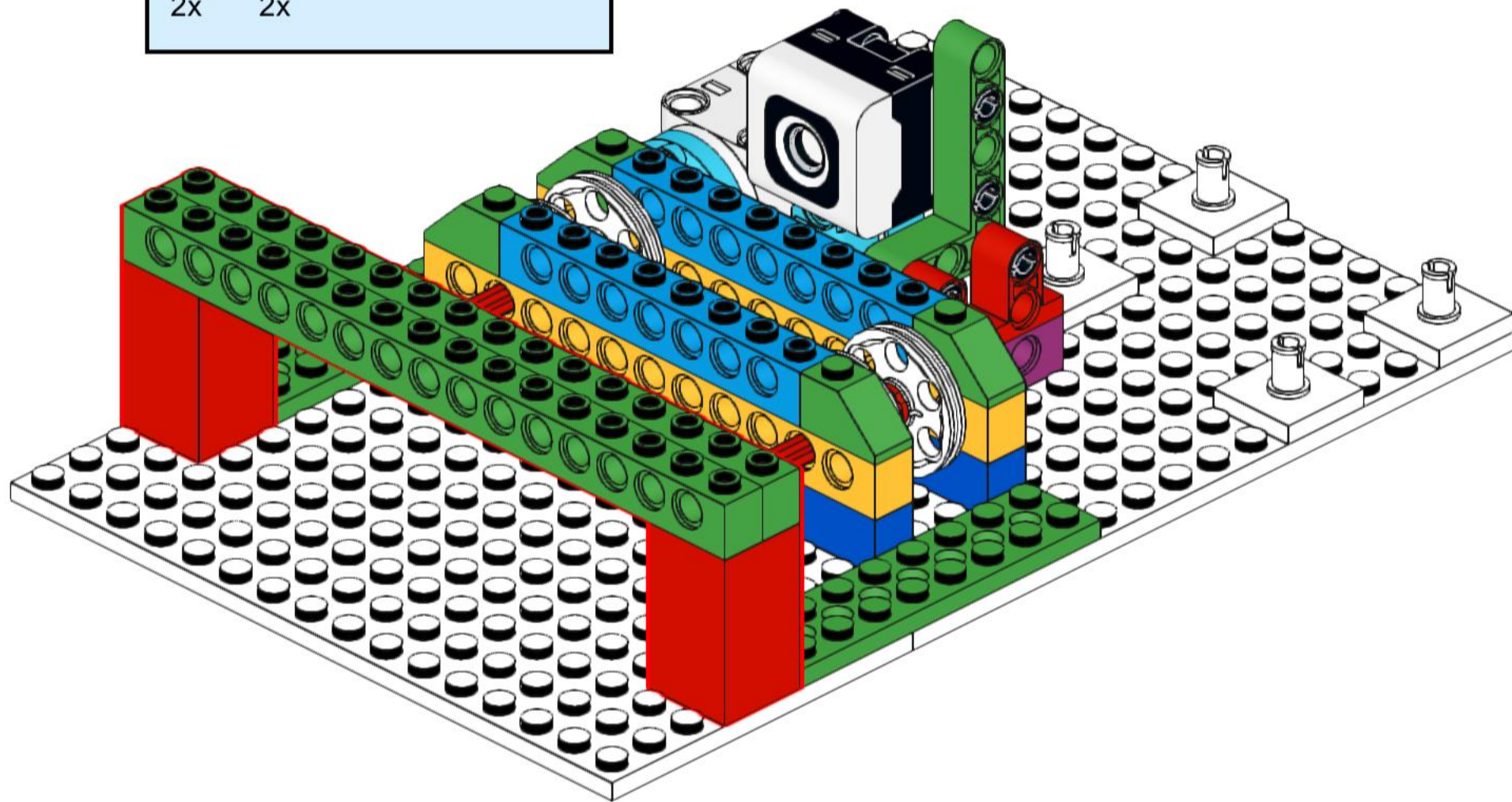
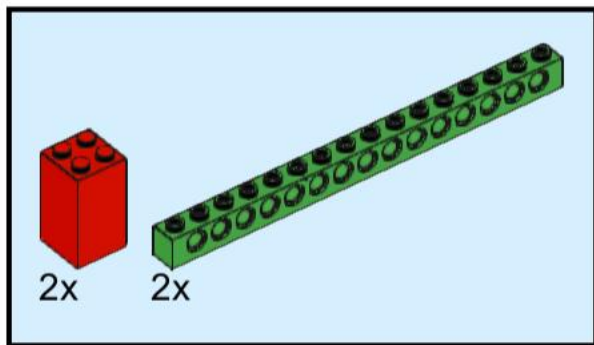

16

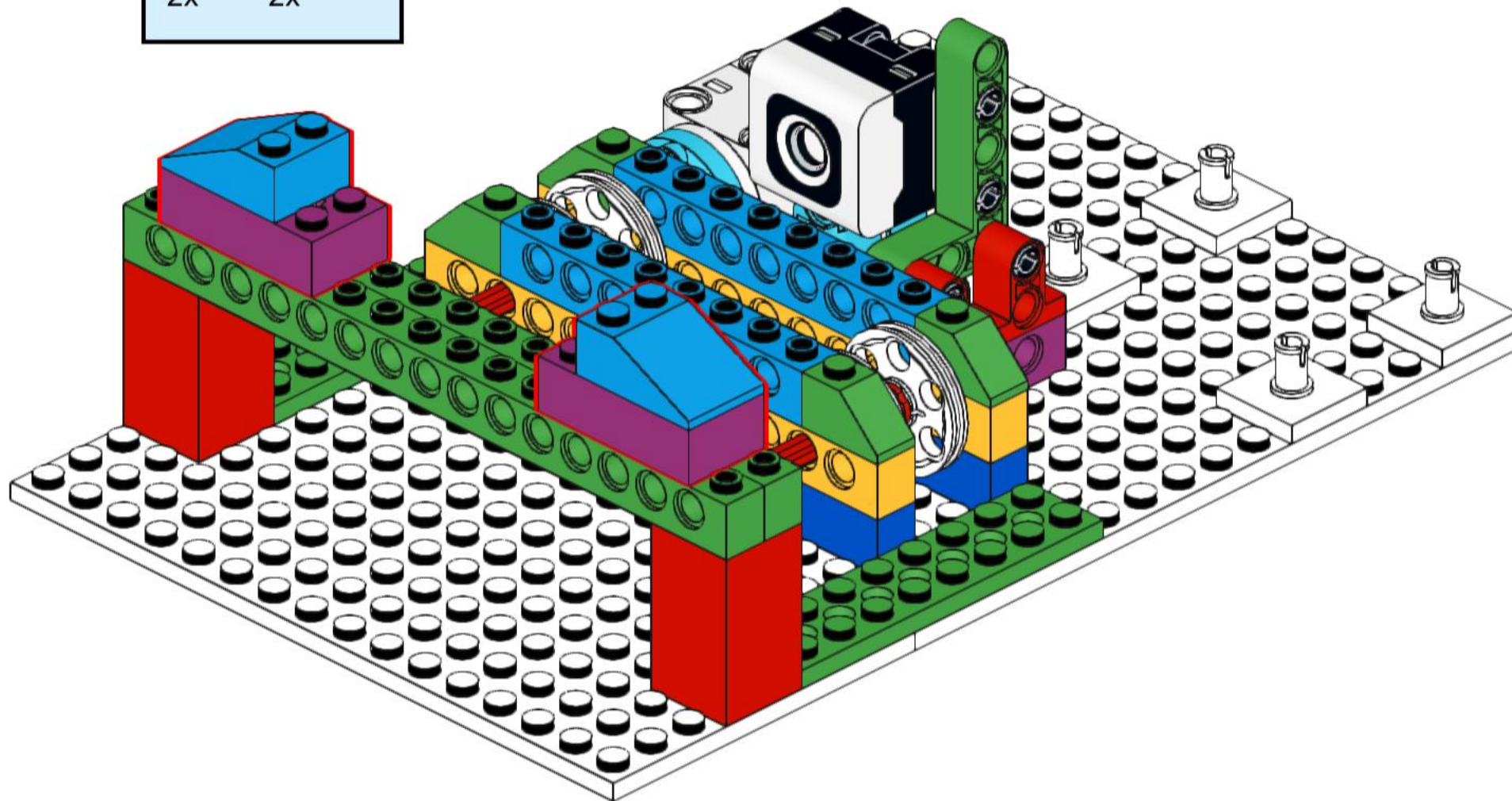
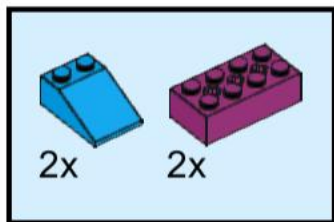

17

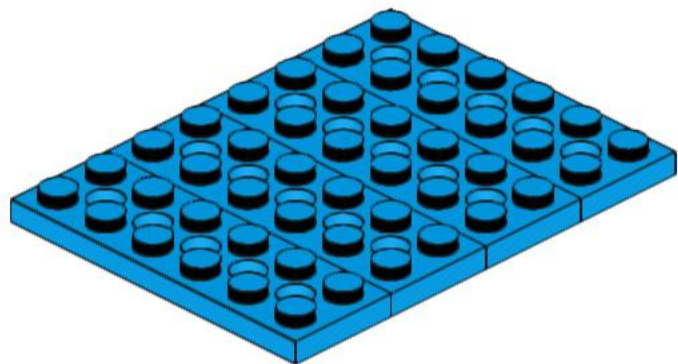
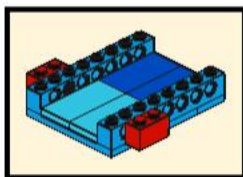
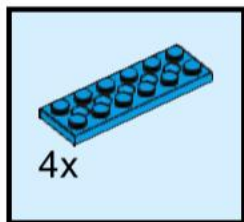

19

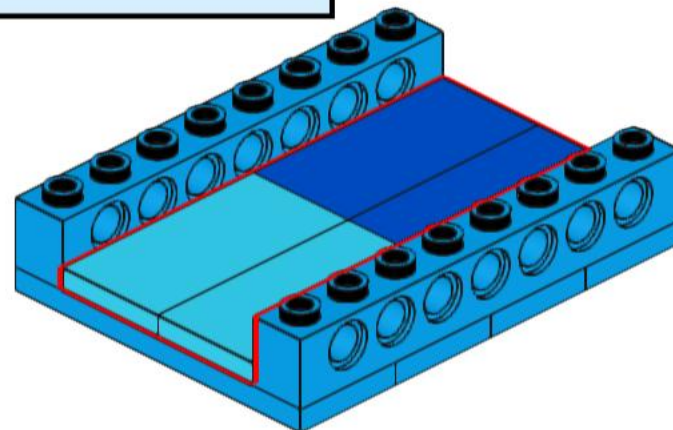
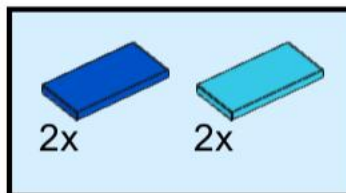

18

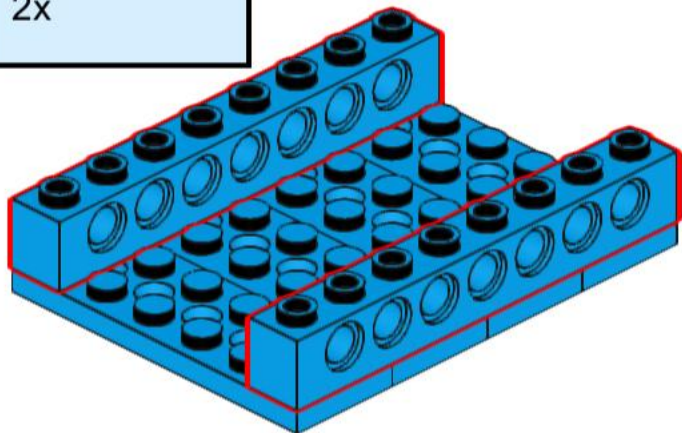
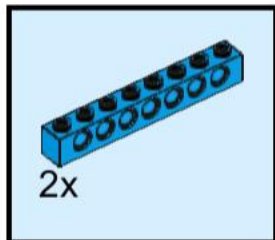

20

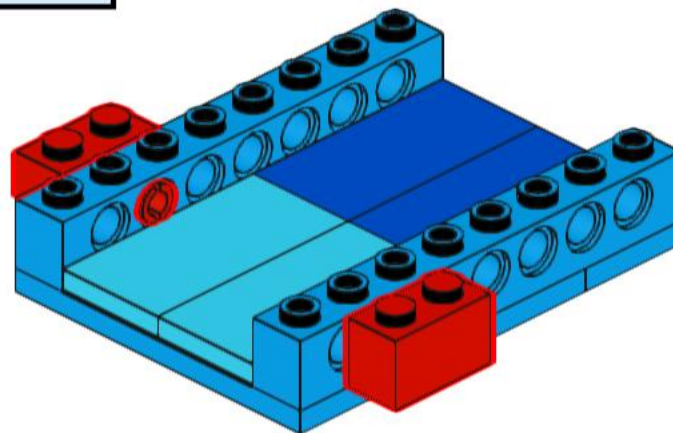
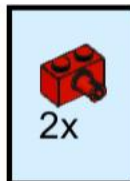

21

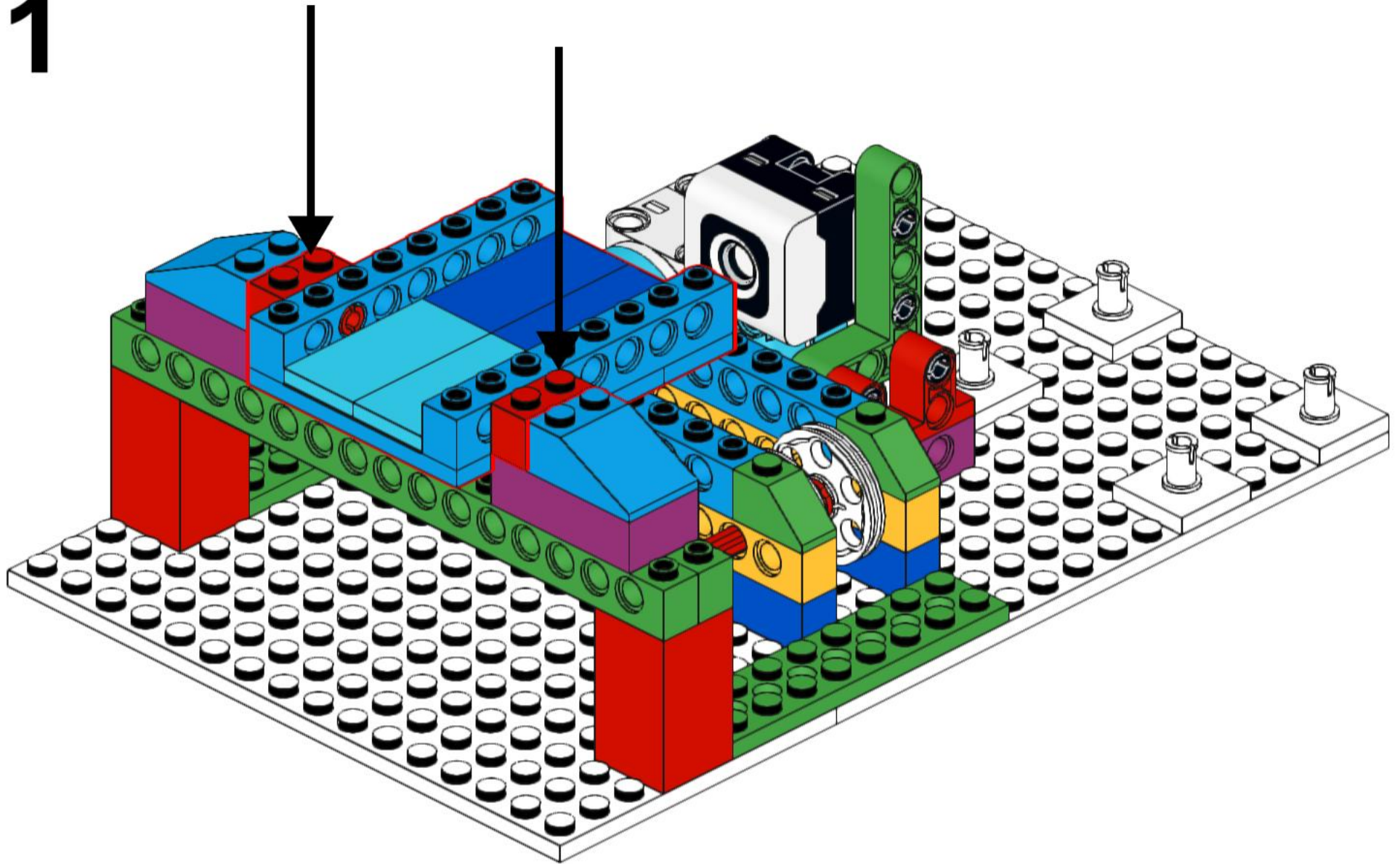

22

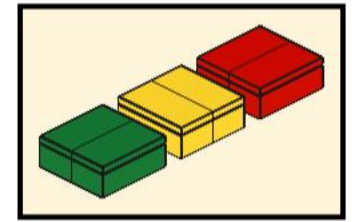
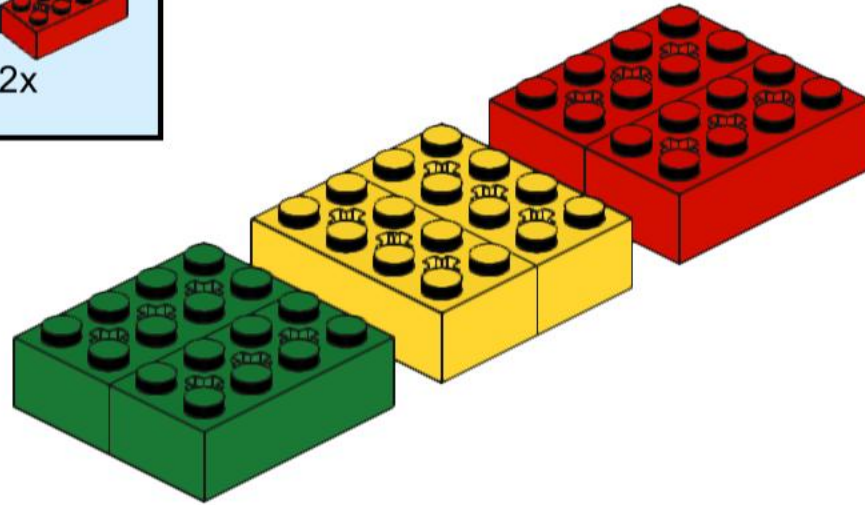
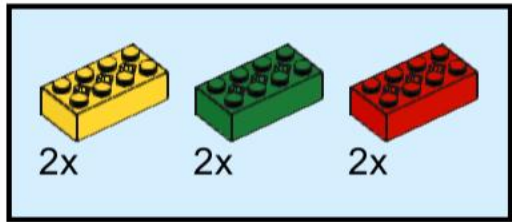

23

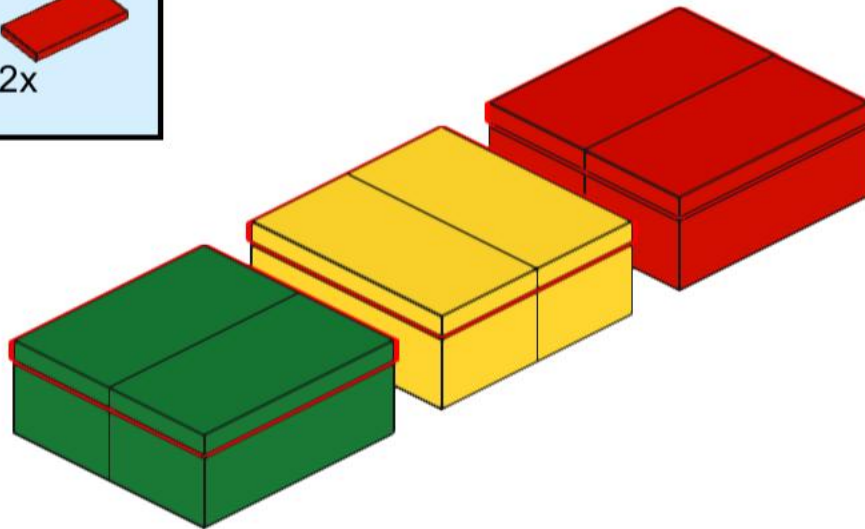
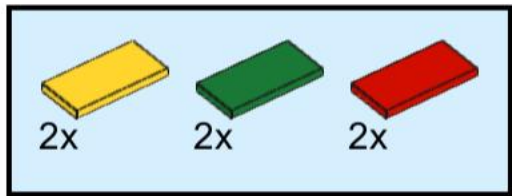

24

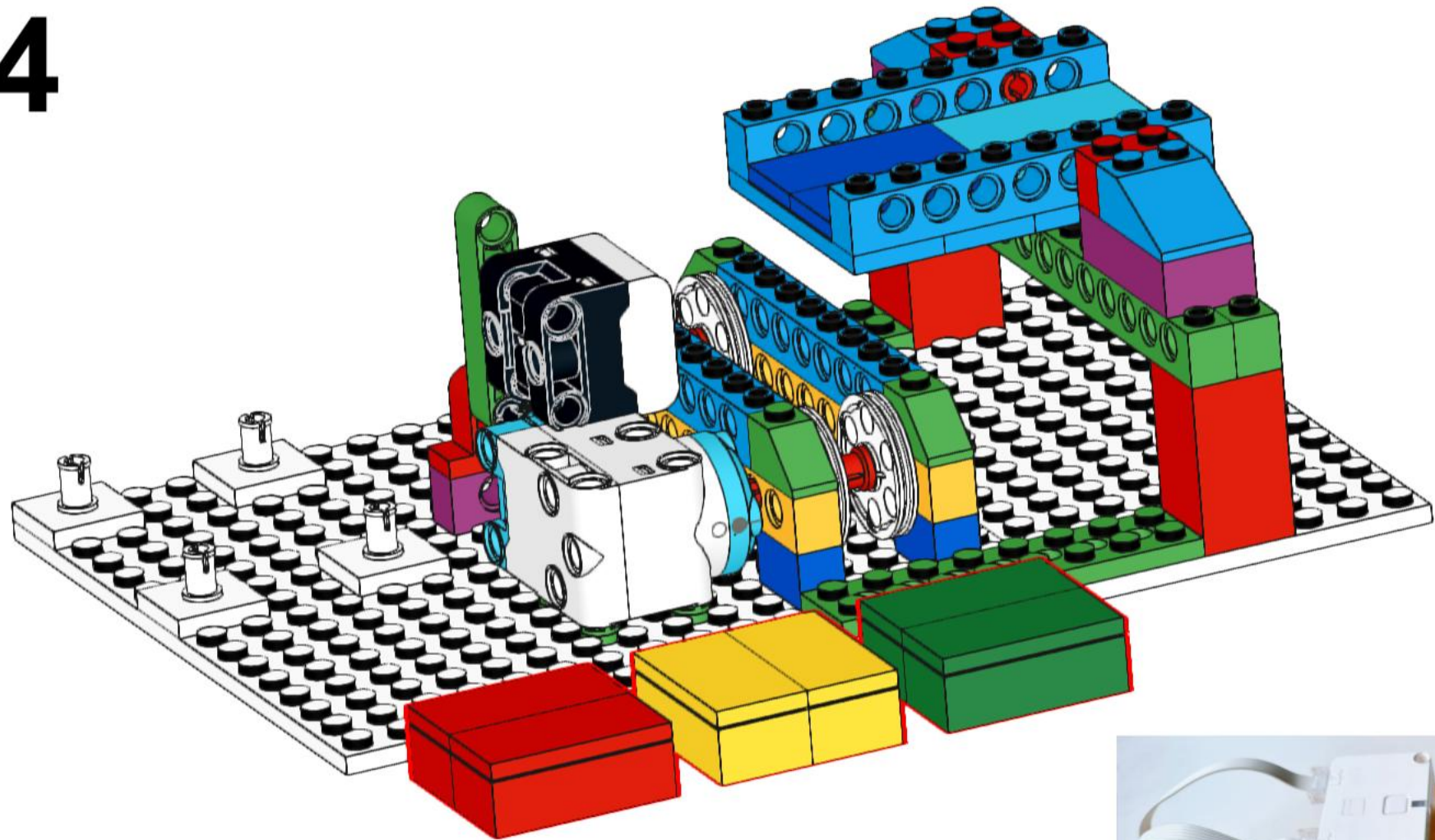

24a: Zet de hub op de vier witte pinnetjes.

24b: Sluit de kabels van de motor en de sensor aan op de hub.

